

# INSTALLATION INSTRUCTION

## 250-LED Pendant

PD-250905



**CAUTION:** To prevent electrical shock, ensure electricity has been turned off at the circuit breaker before beginning.

- Read all instructions before installing.
- Fixture is intended for installation by a licensed electrician in accordance with the National Electrical Code (NEC) and local regulations
- When handling the fixture, do not apply pressure to the LEDs.
- Retain installation instructions for future maintenance reference.

**WARNING:** All parts must be used as indicated in these instructions. This product is designed for use only with the supplied parts and/or accessories designated for use by WAC Lighting. Substitution of parts or accessories not designated for use with this product by WAC Lighting could result in personal injury or property damage, and will void the warranty. Contact an authorized dealer or the manufacturer if any parts are damaged or missing.

**MAINTENANCE NOTE:** Coastal conditions may cause mineral and residue build-up on the fixture. We recommend that customers in coastal areas clean all external surfaces of the fixture once every two weeks with a wet cloth.

**MISE EN GARDE:** Pour éviter tout choc électrique, assurez-vous que le disjoncteur soit mis hors tension avant de commencer.

- Lisez toutes les instructions avant l'installation.
- Le système doit être installé par un électricien licencié conformément au code national de l'électricité (NEC), et également aux règlements locaux.
- Lors de la manipulation du luminaire, n'appuyez pas sur les LED. Tenez-le uniquement par la base.

**ATTENTION:** Toutes les pièces doivent être utilisées comme indiqué dans ces instructions. Ce produit est conçu pour être utilisé seulement avec les pièces et/ou accessoires fournis pour être utilisés avec les produits WAC Lighting. Remplacer des pièces ou accessoires non conçus pour ce produit WAC Lighting pourrait causer des dommages corporels ou matériels et pourrait également causer l'annulation de la garantie. Veuillez contacter un revendeur autorisé ou le fabricant si des pièces manquent ou sont endommagées.

**NOTE D'ENTRETIEN:** Les conditions côtières peut causer une accumulation de minéraux et de résidus sur le luminaire. Nous recommandons aux clients qui résident dans les zones côtières de nettoyer toutes les surfaces externes du luminaire une fois toutes les deux semaines avec un chiffon humide.

### HARDWARE



Wire Connector  
Qty: 3PCS+1 Extra



Mounting Screw  
Qty: 1 Extra

waclighting.com  
Phone (800) 526.2588  
Fax (800) 526.2585

Headquarters/Eastern Distribution Center  
44 Harbor Park Drive  
Port Washington, NY 11050

South East Distribution Center  
1600 Distribution Ct  
Lithia Springs, GA 30122

Central Manufacturing Facility  
1700 South J Elmer Freeway  
Suite 100  
Cedar Hill, TX 75104

Western Distribution Center  
1750 Archibald Avenue  
Ontario, CA 91761

# INSTALLATION INSTRUCTIONS

## 250-LED Pendant

PD-250905

# WAC

### PREPARATION

1. Shut off the power at the circuit breaker and remove existing fixture, including the crossbar.
2. Carefully unpack your new fixture and lay out all the parts on a clear area. Be careful not to lose any small parts necessary for installation.

### MOUNTING THE FIXTURE (Fig. 1)

3. Remove the mounting screws (B) from the fixture, take down the mounting plate.
4. Secure the mounting plate to the junction box using the screws provided with the junction box.

Note: (i) using any other non-original-manufacturer provided junction box screw may result in safety issue;  
 (ii) The concave side of the mounting plate must face out.

5. Adjust the fixture wire length by pushing the cable gripper on the fixture and pulling the wire as desired.

### CONNECTING THE WIRES (Fig. 2)

6. Connect the canopy's input wires to junction box wires as shown in Fig. 2, making sure that all wire connectors (A) are secured. If your outlet box has a green or bare copper ground wire, connect the fixture's ground wire to it. After wires are connected, tuck them carefully inside the junction box.
7. The lamp can switch between five color temperatures (2700K-3000K-3500K-4000K-5000K), which can be adjusted to your preference.

**Note:** Fixture must be powered off to adjust the CCT setting, after each CCT adjustment cycle power on, off then on to show new CCT setting.

### COMPLETING THE INSTALLATION

8. Mount the canopy the mounting plate. Secure the fixture using the mounting screws (B).
9. Secure the lamp body to the ring of the mounting plate. Turn and rotate the lamp body in the direction of the arrow until it stops.

Fig. 1

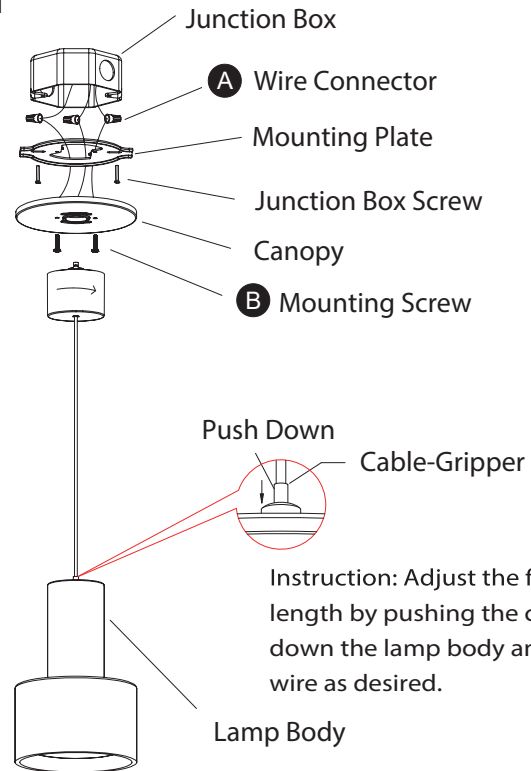

Fig. 2 Wiring

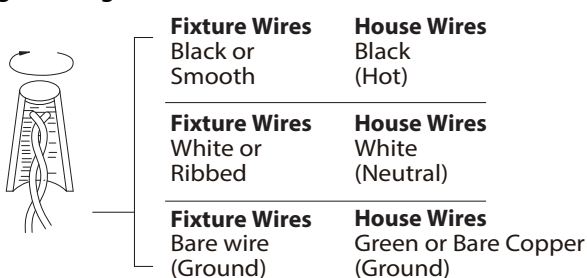
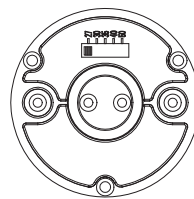

Fig. 3 5CCT Switch



Mounting Back plate Dimensions

