

INSTALLATION INSTRUCTION

LED Pendant

PD403632

dweLED

CAUTION: To prevent electrical shock, ensure electricity has been turned off at the circuit breaker before beginning.

- Read all instructions before installing.
- System is intended for installation by a licensed electrician in accordance with the National Electrical Code (NEC) and local regulations.
- When handling the fixture, do not apply pressure to the LEDs. Hold the fixture by the base only.
- Retain installation instructions for future maintenance reference.

WARNING: All parts must be used as indicated in these instructions. This product is designed for use only with the supplied parts and/or accessories designated for use by dweLED. Substitution of parts or accessories not designated for use with this product by dweLED could result in personal injury or property damage, and will void the warranty. Contact an authorized dealer or the manufacturer if any parts are damaged or missing.

MAINTENANCE NOTE: Coastal conditions may cause mineral and residue build-up on the fixture. We recommend that customers in coastal areas clean all external surfaces of the fixture once every two weeks with a wet cloth.

MISE EN GARDE: Pour éviter tout choc électrique, assurez-vous que le disjoncteur soit mis hors tension avant de commencer.

- Lisez toutes les instructions avant l'installation.
- Le système doit être installé par un électricien licencié conformément au code national de l'électricité (NEC), et également aux règlements locaux.
- Lors de la manipulation du luminaire, n'appuyez pas sur les LED. Tenez-le uniquement par la base.

ATTENTION: Toutes les pièces doivent être utilisées comme indiqué dans ces instructions. Ce produit est conçu pour être utilisé seulement avec les pièces et/ou accessoires fournis pour être utilisés avec les produits dweLED. Remplacer des pièces ou accessoires non conçus pour ce produit dweLED pourrait causer des dommages corporels ou matériels et pourrait également causer l'annulation de la garantie. Veuillez contacter un revendeur autorisé ou le fabricant si des pièces manquent ou sont endommagées.

NOTE D'ENTRETIEN: Les conditions côtières peut causer une accumulation de minéraux et de résidus sur le luminaire. Nous recommandons aux clients qui résident dans les zones côtières de nettoyer toutes les surfaces externes du luminaire une fois toutes les deux semaines avec un chiffon humide.

HARDWARE

A



Wire Connector

Qty: 4pcs

B

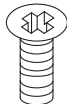

Mounting Screw

Qty: 1pc

C

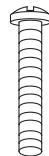

Junction Box Screw

Qty: 3pcs

wacighting.com

Phone (800) 526.2588

Fax (800) 526.2585

Headquarters, East Manufacturing Facility

44 Harbor Park Drive

Port Washington, NY 11050

South East Manufacturing Facility

1600 Distribution Ct

Lithia Springs, GA 30122

Central Manufacturing Facility

1700 South J Elmer Freeway, Ste 100

Cedar Hill, TX 75104

West Manufacturing Facility

1750 S Archibald Ave

Ontario, CA 91761

INSTALLATION INSTRUCTION
LED Pendant
 PD403632

dweLED

Fig.1

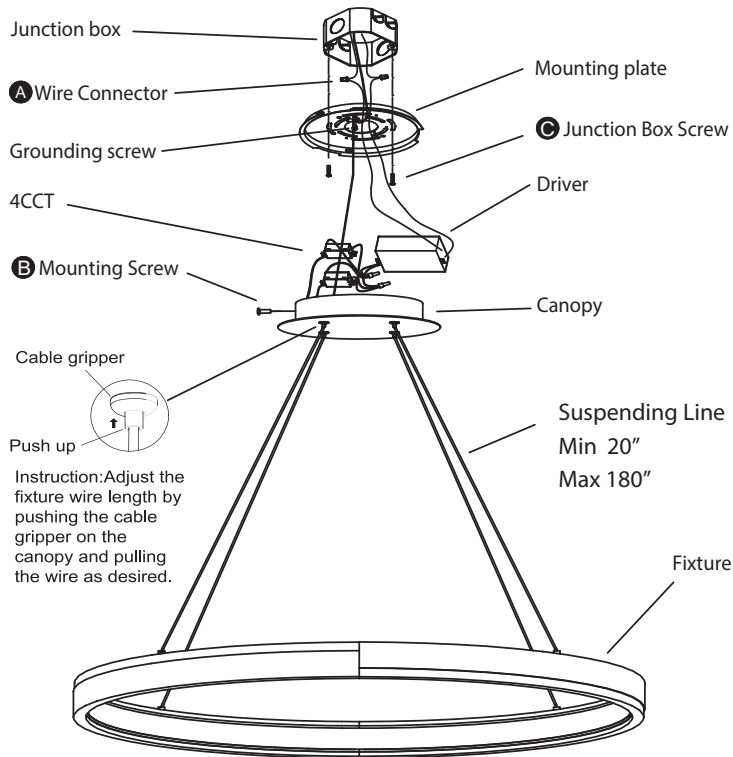

Fig.2 Wiring

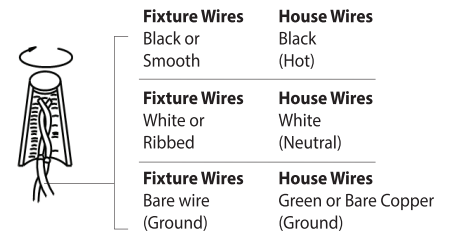

Fig.3 4CCT Switch

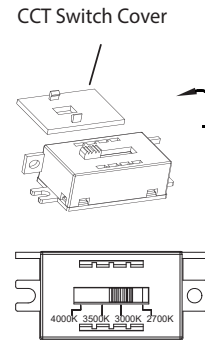

Fig.4 Mounting Plate Dimensions

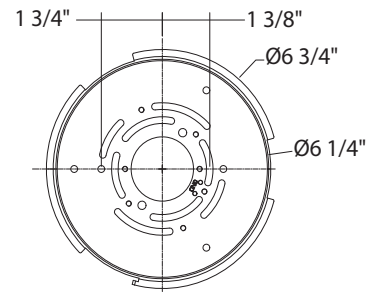
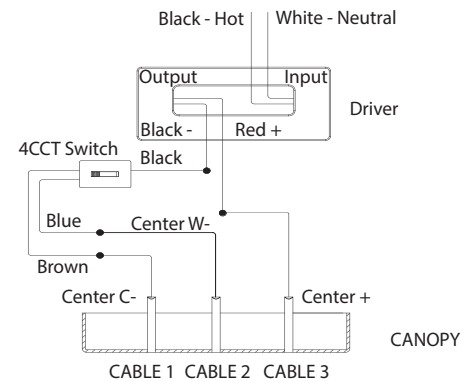

Fig.5 Driver Wires



PREPARATION

- Carefully unpack your new fixture and lay out all the parts on a clear area. Be careful not to lose any parts necessary for installation.
- Shut off the power at the circuit breaker and remove existing fixture, including the crossbar.

MOUNTING THE FIXTURE (Fig. 1)

- Remove the mounting screws (B) from the fixture, and remove the mounting plate(Fig. 1).
- Secure the mounting plate to the junction box using standard junction box screws(C).
 Note: (i) Using any other non-original-manufacturer provided junction box screw may result in safety issue;
 (ii) The side of the mounting plate marked "GND" must face out.
- Adjust the fixture wire length by pushing the cable gripper on the canopy and pulling the wire as desired.
 - Before securing the canopy in place, it is recommended to retract or extend the wire within the canopy to a desirable length.
 - Due to limited space within the canopy, shorten the cable as necessary to make the installation easier. Make sure to identify and label all the wiring properly before any trimming/shortening .

CONNECTING THE WIRES (Fig. 2)

- Connect the fixture, CCT switch, and driver's output wires to center cable as shown in Fig. 5, red to the Center +, black to the black, blue to the Center W-, brown to the Center C-, make sure that wire connectors(A) are secured. Then tuck them inside the canopy.
- The lamp can switch between four color temperatures (2700K-3000K-3500K-4000K), which can be adjusted to your preference with the switch in the canopy (Fig. 3).
 Note: The switch comes with a detachable cover, remove the cover prior to adjusting the color temperature, reattach the cover after adjustment is made.Two 4CCT switches need to be adjusted to the same color temperature simultaneously in order to complete the color temperature adjustment of the lamp.

Note: Fixture must be powered off to adjust the CCT setting, after each CCT adjustment cycle power on, off then on to show new CCT setting.

- Connect the driver's input wires to junction box wires as shown in Fig. 2, make sure that all wire connectors(A) are secured. If your outlet box has a green or bare copper ground wire, connect the fixture's ground wire to it. Otherwise, connect the fixture's ground wire directly to the mounting plate using the screw provided. After wires are connected, tuck them carefully inside the junction box.

COMPLETING THE INSTALLATION (Fig. 1)

- Secure the fixture to the mounting plate using the mounting screw (B). (Fig. 1)

waclighting.com	Headquarters, East Manufacturing Facility	South East Manufacturing Facility	Central Manufacturing Facility	West Manufacturing Facility
Phone (800) 526.2588	44 Harbor Park Drive	1600 Distribution Ct	1700 South J Elmer Freeway, Ste 100	1750 S Archibald Ave
Fax (800) 526.2585	Port Washington, NY 11050	Lithia Springs, GA 30122	Cedar Hill, TX 75104	Ontario, CA 91761