

INSTALLATION INSTRUCTION

Volta 4.5" Tunable White - Wall Wash Round Trim

R4RWT, R4RWL

WAC®

SAFETY INSTRUCTION

IMPORTANT: Never attempt any work without shutting off the electricity.

- Read all instructions before installing.
- System is intended for installation by a qualified electrician in accordance with the National Electrical Code and local regulations.
- Go to the main fuse box, or circuit breaker. Place the main power switch in the "OFF" position and unscrew the fuse(s) or switch "OFF" the circuit breaker switch(es) that control the power to the fixture or room that you are working on.
- Place the wall switch in the "OFF" position.

AVERTISSEMENT

IMPORTANT: Coupez l'électricité avant TOUTE manipulation.

- Lisez toutes les instructions avant d'installer.
- Système est destiné à être installé par un électricien qualifié en conformité avec le code national de l'électricité et les règlements locaux.
- Accédez au panneau central de disjoncteurs ou de fusibles de votre demeure et placez l'interrupteur principal en position d'arrêt (« OFF »).
- Placez l'interrupteur mural en position d'arrêt (« OFF »).

CAUTION:

All parts must be used as indicated in these instructions. Do not substitute any parts, leave parts, or use any parts that are worn out or broken. Failure to follow could invalidate the ETL/cETL listing of this fixture.

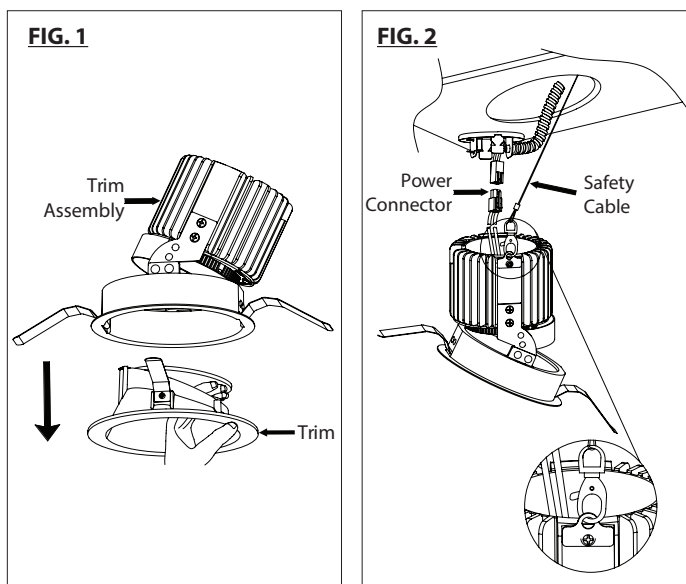

TRIM MODEL

Refer to specification sheets for compatible housing and trim details. Follow appropriate housing instructions to begin installation.

TRIM INSTALLATION

1. Remove trim from trim assembly (See FIG. 1).
2. Raise trim assembly to ceiling cutout and connect power connector and safety cable (See FIG. 2).
3. Install connector cap onto top of trim assembly, careful not to pinch power wiring. Make sure the cap wire cable aligns with the notch on the top of heat sink (See FIG. 3).

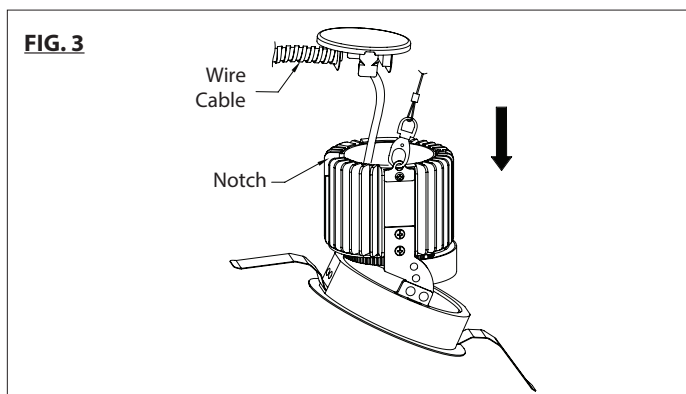

wacighting.com

Phone (800) 526.2588

Fax (800) 526.2585

Headquarters, East Manufacturing Facility

44 Harbor Park Drive

Port Washington, NY 11050

South East Manufacturing Facility

1600 Distribution Ct

Lithia Springs, GA 30122

Central Manufacturing Facility

1700 South J Elmer Freeway, Ste 100

Cedar Hill, TX 75104

West Manufacturing Facility

1750 S Archibald Ave

Ontario, CA 91761

INSTALLATION INSTRUCTION

Volta 4.5" Tunable White - Wall Wash Round Trim

R4RWT, R4RWL

WAC®

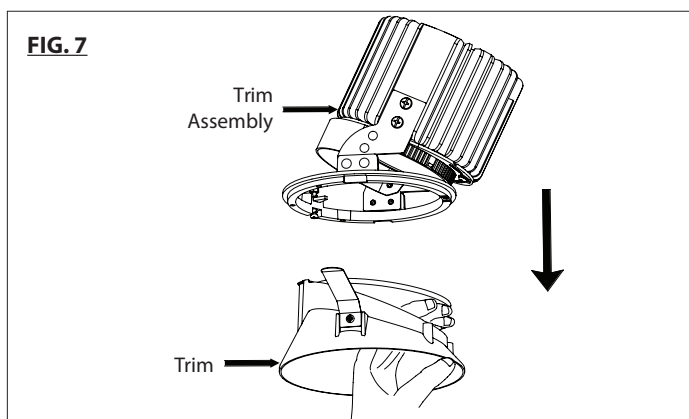
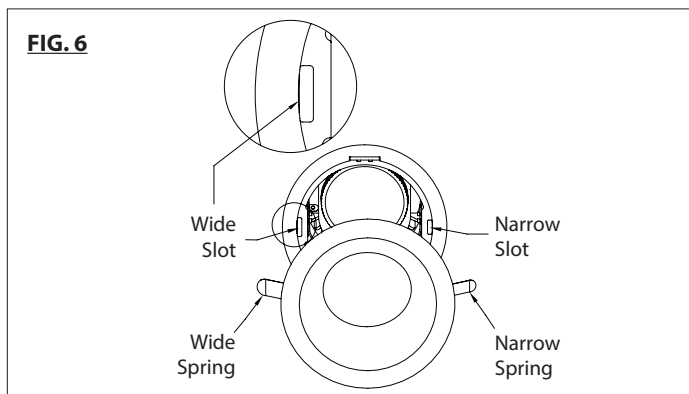
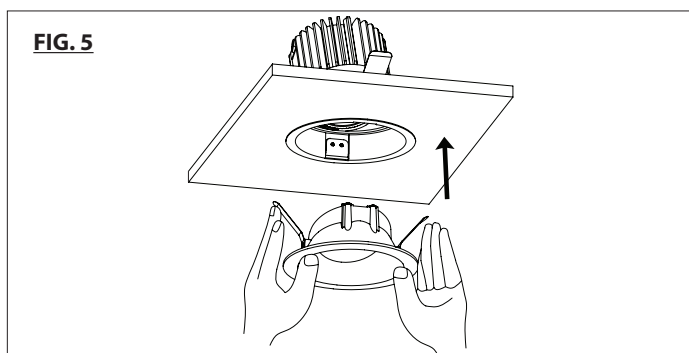
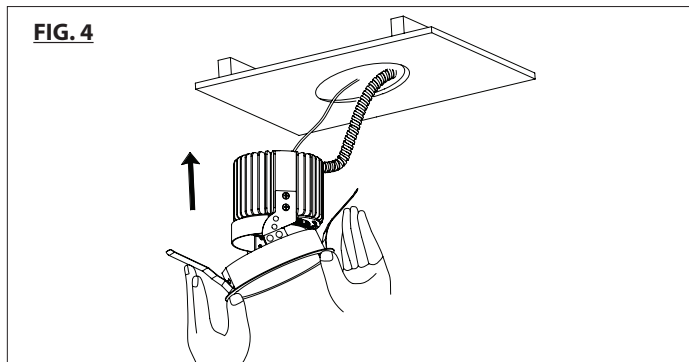

4. Fold trim assembly mounting springs inward and insert trim assembly into ceiling cutout with the angle of the heat sink opposite wall to be illuminated. Be sure once installed, trim assembly is flush and secure (See **FIG. 4**).
5. Raise trim up to the trim assembly until the trim is flush with ceiling surface. Be sure trim springs go into appropriate slots in the trim assembly (See **FIG. 5 & 6**).

TRIMLESS INSTALLATION

1. Remove trim from trim assembly (See **FIG. 7**).

wacighting.com
Phone (800) 526.2588
Fax (800) 526.2585

Headquarters, East Manufacturing Facility
44 Harbor Park Drive
Port Washington, NY 11050

South East Manufacturing Facility
1600 Distribution Ct
Lithia Springs, GA 30122

Central Manufacturing Facility
1700 South J Elmer Freeway, Ste 100
Cedar Hill, TX 75104

West Manufacturing Facility
1750 S Archibald Ave
Ontario, CA 91761

INSTALLATION INSTRUCTION

Volta 4.5" Tunable White - Wall Wash Round Trim

R4RWT, R4RWL

WAC®

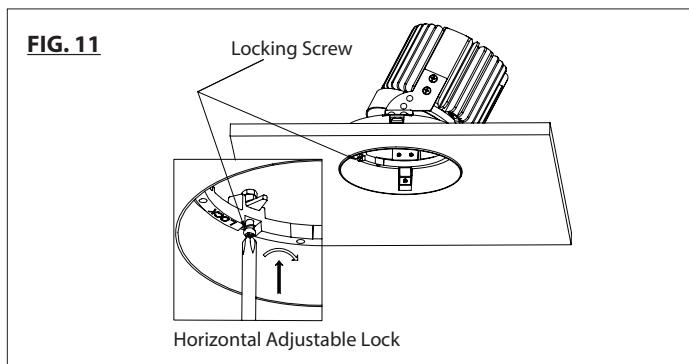
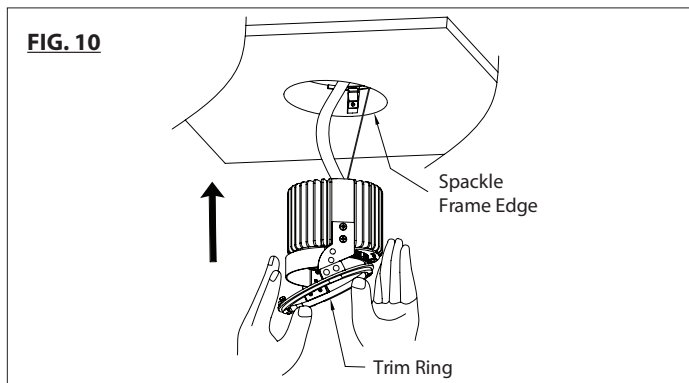
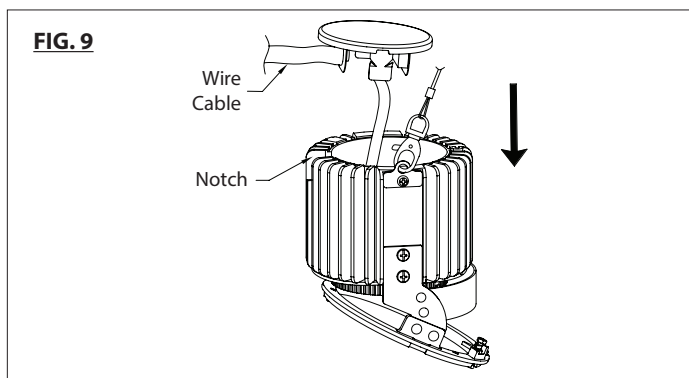
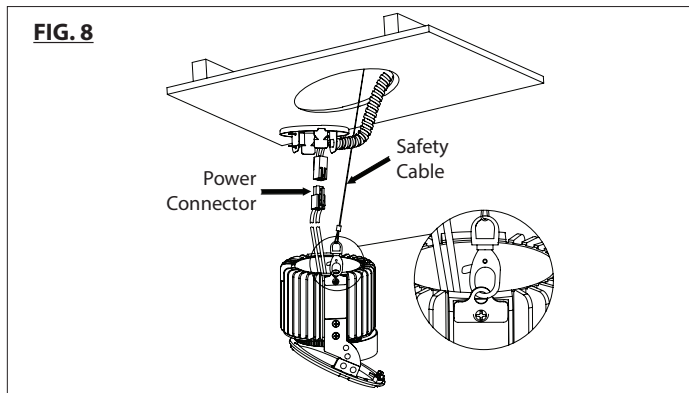

2. Raise trim assembly to ceiling cutout and connect power connector and safety cable (See **FIG. 8**).
3. Install connector cap onto top of trim assembly, careful not to pinch power wiring. Make sure the cap wire cable aligns with the notch on the top of heat sink (See **FIG. 9**).
4. After power and safety chain connections, insert trim assembly into spackle frame. To make the installation easier, make sure the trim ring is parallel to the spackle frame edge inside opening (See **FIG. 10**).
5. Adjust trim assembly to the desired location and lock by using Philips-head screw driver to secure horizontal adjustable lock (See **FIG. 11**).

wacighting.com

Phone (800) 526.2588

Fax (800) 526.2585

Headquarters, East Manufacturing Facility

44 Harbor Park Drive

Port Washington, NY 11050

South East Manufacturing Facility

1600 Distribution Ct

Lithia Springs, GA 30122

Central Manufacturing Facility

1700 South J Elmer Freeway, Ste 100

Cedar Hill, TX 75104

West Manufacturing Facility

1750 S Archibald Ave

Ontario, CA 91761

INSTALLATION INSTRUCTION

Volta 4.5" Tunable White - Wall Wash Round Trim

R4RWT, R4RWL

WAC®

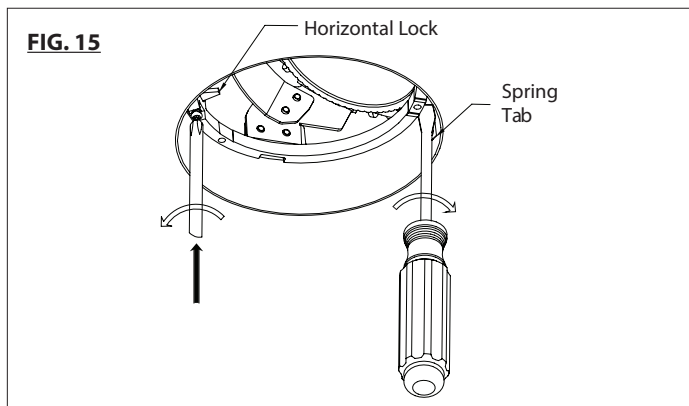
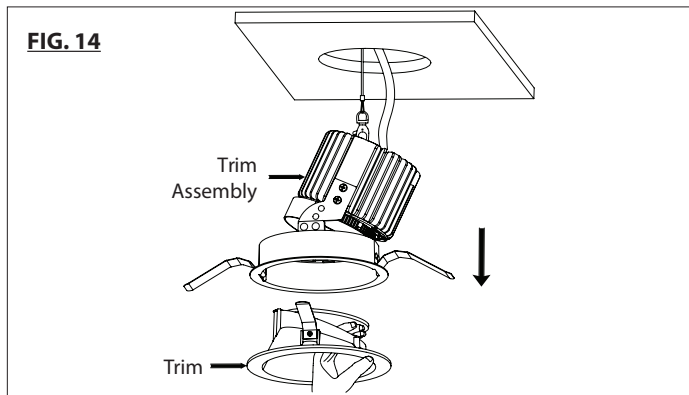
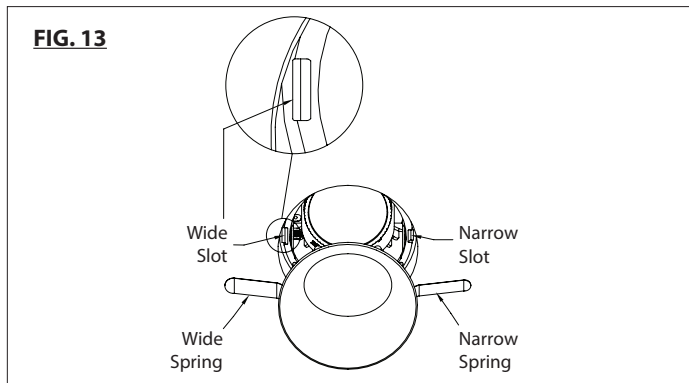
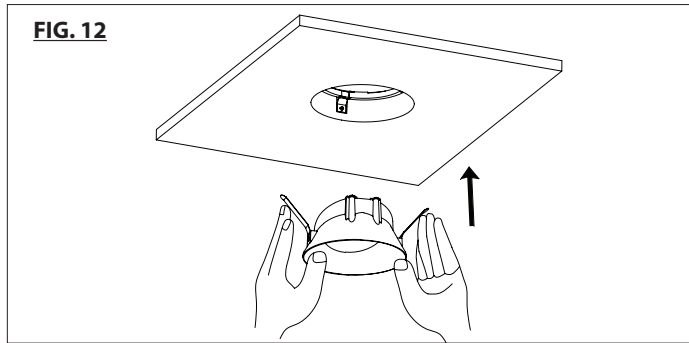

6. Raise trim up to the trim assembly until the trim is flush with ceiling surface. Be sure trim springs go into appropriate slots in the trim assembly (See **FIG. 12 & 13**).

TRIM ASSEMBLY REMOVAL

1. Power off fixture and let fixture cool down.
2. a. Remove trim from the trim assembly first, then the trim assembly from the ceiling or fixture aperture (See **FIG. 14**).
b. To remove the Trimless assembly, use the Philips-head driver to lose the locking screw and the flat head screw driver to release the spring tab on aperture ring (See **FIG. 15**).

wacighting.com

Phone (800) 526.2588

Fax (800) 526.2585

Headquarters, East Manufacturing Facility

44 Harbor Park Drive

Port Washington, NY 11050

South East Manufacturing Facility

1600 Distribution Ct

Lithia Springs, GA 30122

Central Manufacturing Facility

1700 South J Elmer Freeway, Ste 100

Cedar Hill, TX 75104

West Manufacturing Facility

1750 S Archibald Ave

Ontario, CA 91761