

# INSTALLATION INSTRUCTIONS

## VENTRIX - Niveous Pendant

S2PD02-2, S2PD02-3

**VENTRIX**  
BY WAC

### CAUTION: TO PREVENT ELECTRICAL SHOCK, ENSURE ELECTRICITY HAS BEEN TURNED OFF AT THE CIRCUIT BREAKER BEFORE BEGINNING.

- Read all instructions before installing.
- System is intended for installation by a licensed electrician in accordance with the National Electrical Code (NEC) and local regulations.
- When handling the fixture, do not apply pressure to the LEDs. Hold the fixture by the base only.
- Retain installation instructions for future maintenance reference.
- VENTRIX fixtures and channels feature separate data and power conductor systems. During installation and use, do not short the data or power conductors together by any means or damage may occur.

**WARNING:** All parts must be used as indicated in these instructions. This product is designed for use only with the supplied parts and/or accessories designated for use by WAC Lighting. Substitution of parts or accessories not designated for use with this product by WAC Lighting could result in personal injury or property damage, and will void the warranty. Contact an authorized dealer or the manufacturer if any parts are damaged or missing.

### MISE EN GARDE: POUR ÉVITER TOUT CHOC ÉLECTRIQUE, ASSUREZ-VOUS QUE LE DISJONCTEUR SOIT MIS HORS TENSION AVANT DE COMMENCER.

- Lisez toutes les instructions avant l'installation.
- Le système doit être installé par un électricien licencié conformément au code national de l'électricité (NEC), et également aux règlements locaux.
- Lors de la manipulation du luminaire, n'appuyez pas sur les LED. Tenez-le uniquement par la base.

**ATTENTION:** Toutes les pièces doivent être utilisées comme indiqué dans ces instructions. Ce produit est conçu pour être utilisé seulement avec les pièces et/ou accessoires fournis pour être utilisés avec les produits WAC Lighting. Remplacer des pièces ou accessoires non conçus pour ce produit WAC Lighting pourrait causer des dommages corporels ou matériels et pourrait également causer l'annulation de la garantie. Veuillez contacter un revendeur autorisé ou le fabricant si des pièces manquent ou sont endommagées.

### OVERALL FIXTURE DIMENSIONS

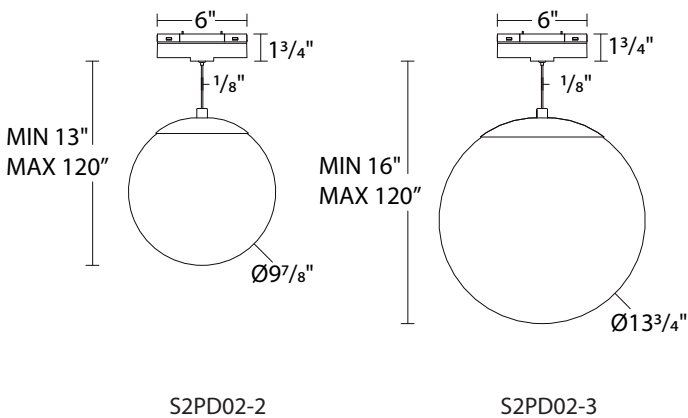

### FIXTURE OVERVIEW

VENTRIX Niveous Pendants are intended for use on WAC Lighting's VENTRIX Channel systems.

LED LUMINAIRE	VENTRIX SYSTEM
S2PD02-2, S2PD02-3	48VDC VENTRIX System

SPECIFICATIONS	
Input:	48VDC
Installation:	VENTRIX System (Ceiling Mounted in Suspended, Surface, & Recessed Profiles)
Dimming:	Via VENTRIX Connected Power Unit. Refer to CPU Specifications.

wacighting.com

Phone (800) 526.2588

Fax (800) 526.2585

Headquarters, East Manufacturing Facility

44 Harbor Park Drive

Port Washington, NY 11050

South East Manufacturing Facility

1600 Distribution Ct

Lithia Springs, GA 30122

Central Manufacturing Facility

1700 South J Elmer Freeway, Ste 100

Cedar Hill, TX 75104

West Manufacturing Facility

1750 S Archibald Ave

Ontario, CA 91761

# INSTALLATION INSTRUCTIONS

## VENTRIX - Niveous Pendant

S2PD02-2, S2PD02-3

**VENTRIX**  
BY WAC

### PREPARATION:

1. Shut off the power at the circuit breaker and ensure adequate room to install the new fixture on the VENTRIX Channel system.
2. Carefully unpack your new fixture and lay out all the parts on a clear area. Be careful not to lose any parts necessary for installation.

### ASSEMBLING THE PENDANT BODY AND GLASS:

The pendant body and glass are independently packaged, and must be assembled before installation to the VENTRIX system.

1. Arrange the pendant body and glass to allow installation to the module bracket. (See **FIG. 1**).
2. Install the module bracket to the glass. (See **FIG. 2**).
3. Attach the cover to the glass and module bracket by screwing the cable nut to the thread atop the module bracket. (See **FIG. 3**).
4. Adjust the cable nut and glass position such that the pendant body hangs symmetrically when suspended. (See **FIG. 4**).

**NOTE:** Each pendant glass is balanced to its designated pendant body. Glass components should NOT be mixed between Niveous fixtures.

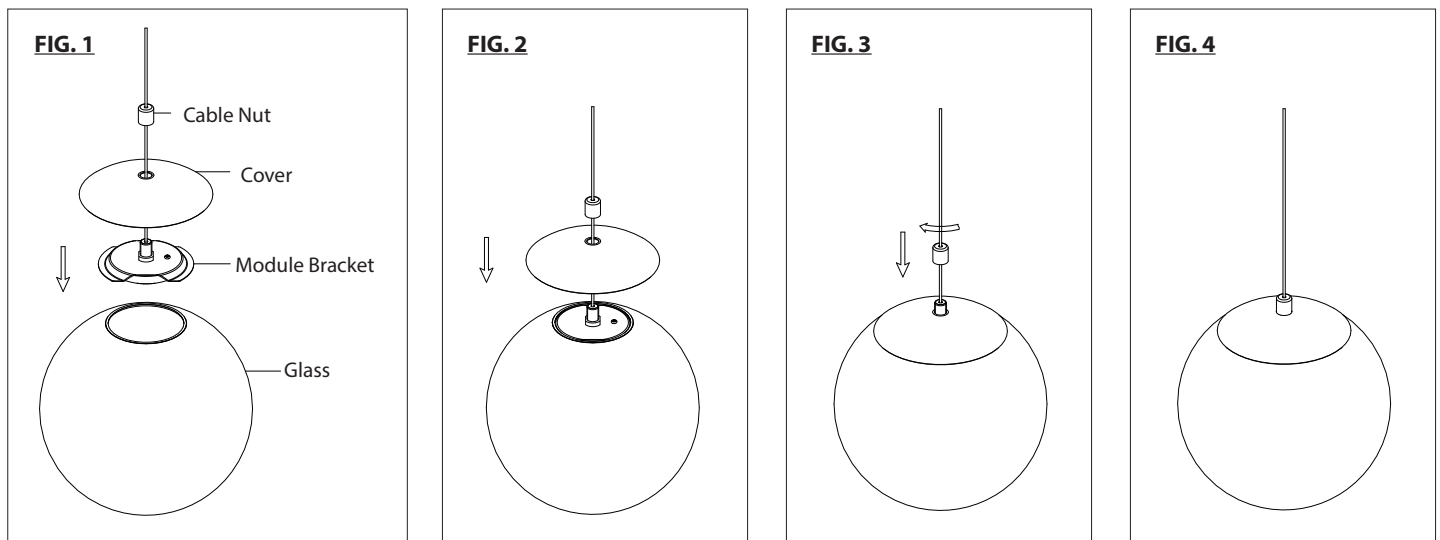

### FIXTURE INSTALLATION TO VENTRIX SYSTEM:

The fixture features a VENTRIX adapter for power and mechanical connection to the installed VENTRIX channel system.

1. This fixture may be installed into horizontal and downward facing VENTRIX channel systems such that pendant cable can hang straight with gravity. (See **FIG. 5**).
2. Fixtures are polarity agnostic, and may be installed in VENTRIX channel in either orientation. (See **FIG. 6**).

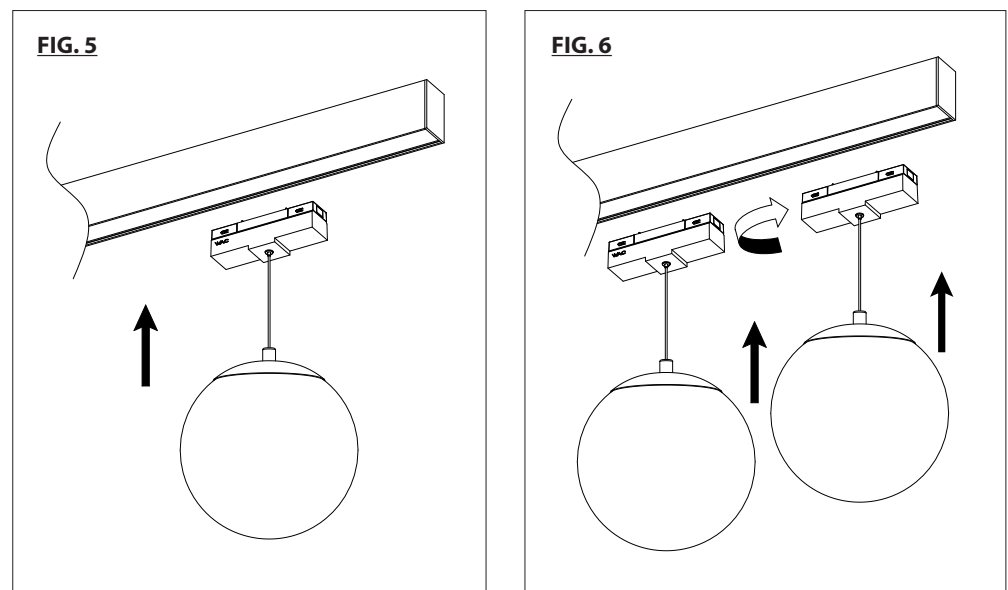

wacighting.com

Phone (800) 526.2588

Fax (800) 526.2585

Headquarters, East Manufacturing Facility

44 Harbor Park Drive

Port Washington, NY 11050

South East Manufacturing Facility

1600 Distribution Ct

Lithia Springs, GA 30122

Central Manufacturing Facility

1700 South J Elmer Freeway, Ste 100

Cedar Hill, TX 75104

West Manufacturing Facility

1750 S Archibald Ave

Ontario, CA 91761

# INSTALLATION INSTRUCTIONS

## VENTRIX - Niveous Pendant

S2PD02-2, S2PD02-3

VENTRIX  
BY WAC

### FIXTURE INSTALLATION TO VENTRIX SYSTEM (CONTINUED):

3. Insert the adapter into the channel slot. Ensure the adapter is parallel to the channel during installation. Push the adapter into the channel until fully secured. (See **FIG. 7**). **NOTE:** Fixture adapters also feature magnets to aid in fixture locating. (See **FIG. 8**).

**CAUTION:** Prior to installation in channel, clear any debris from channel bus bar and fixture, particularly on magnetic surfaces. Any conductive elements have potential to cause electrical shorting resulting in damage.

4. Review connection, be sure both sets of locking tabs are secured in channel prior to finishing installation.

**FIG. 7**

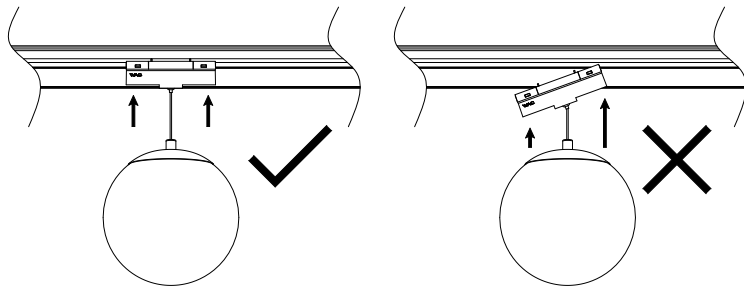

**FIG. 8**

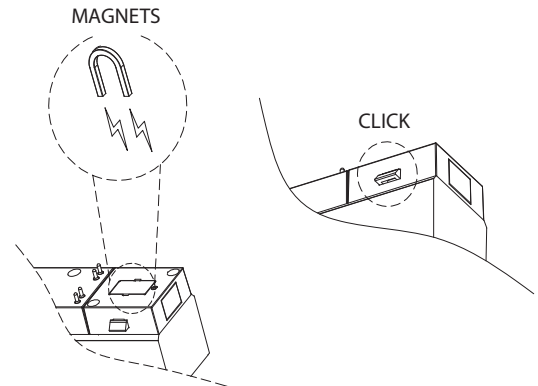

### RELOCATING THE FIXTURE IN CHANNEL:

While installed to the VENTRIX system, the fixture may be relocated.

1. By hand, relocate the fixture within a channel by pushing the adapter in the desired direction. (See **FIG. 9**).
2. Fixtures cannot be relocated between channels. It must be removed, repositioned, and then installed from one channel to another. (See **FIG. 10**).

**FIG. 9**

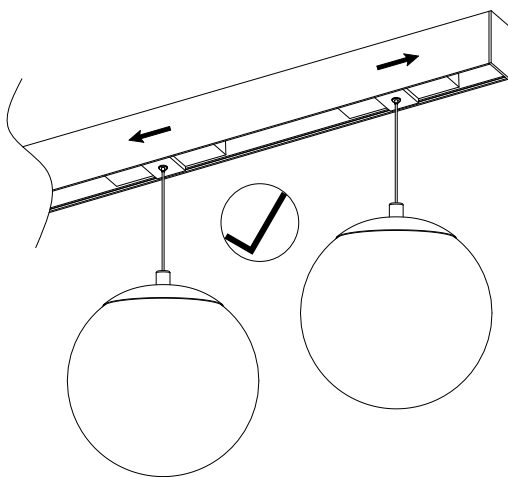

**FIG. 10**

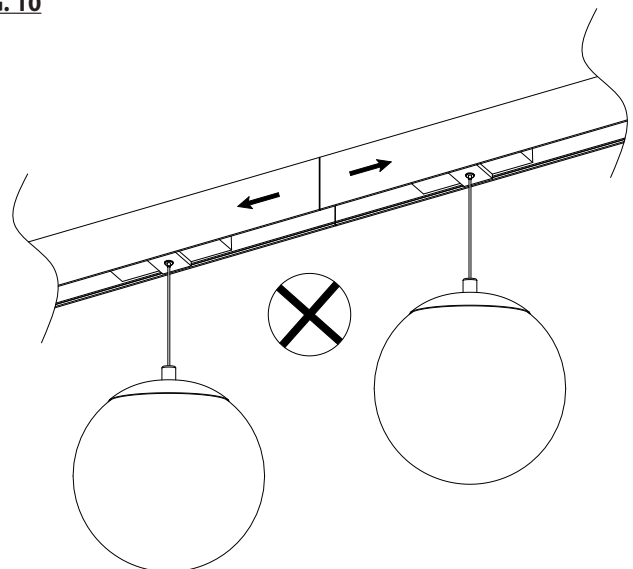

wacighting.com

Phone (800) 526.2588

Fax (800) 526.2585

Headquarters, East Manufacturing Facility

44 Harbor Park Drive

Port Washington, NY 11050

South East Manufacturing Facility

1600 Distribution Ct

Lithia Springs, GA 30122

Central Manufacturing Facility

1700 South J Elmer Freeway, Ste 100

Cedar Hill, TX 75104

West Manufacturing Facility

1750 S Archibald Ave

Ontario, CA 91761

# INSTALLATION INSTRUCTIONS

## VENTRIX - Niveous Pendant

S2PD02-2, S2PD02-3

VENTRIX  
BY WAC

### REMOVING THE FIXTURE FROM THE CHANNEL:

1. By hand, engage and press both push buttons on the adapter. While both push buttons are pressed, pull the adapter away from the channel, until the adapter is clear of the channel. **NOTE:** Ensure the adapter is parallel to the channel during removal. (See **FIG. 11**).
2. To enable fixture removal from channel, maintain free channel space of 1.5" on each side of adapter to enable access to releasing locking tabs.

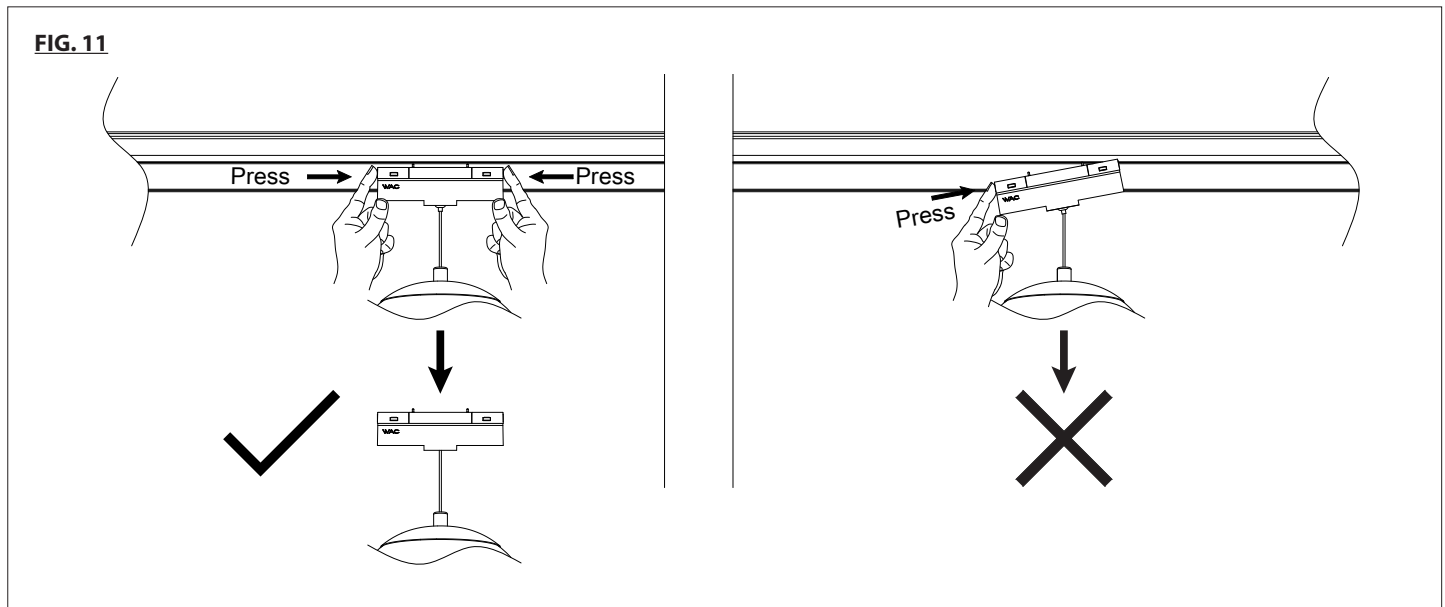

### ADJUSTING SUSPENSION HEIGHT:

The pendant VENTRIX adapter allows for suspension cable height adjustment via on-board cable-gripper. The suspension cable may be cut and spliced within the VENTRIX adapter. For smaller, fine-tuned adjustments, up to 6 inches of suspension cable may be stored within the VENTRIX adapter.

#### For General Suspension Height Adjustment (Wire Splice Required)

1. Ensure the fixture and VENTRIX adapter are removed from the VENTRIX Channel and the pendant end of the fixture is in a stable position. Using a Philips screwdriver, remove and store the screws used to secure the driver cover to the VENTRIX adapter. Remove the driver cover from the VENTRIX adapter. (See **FIG. 12**).
2. Adjust the suspension cable to the preferred height, by pushing the sleeve of the cable-gripper. (See **FIG. 13**).

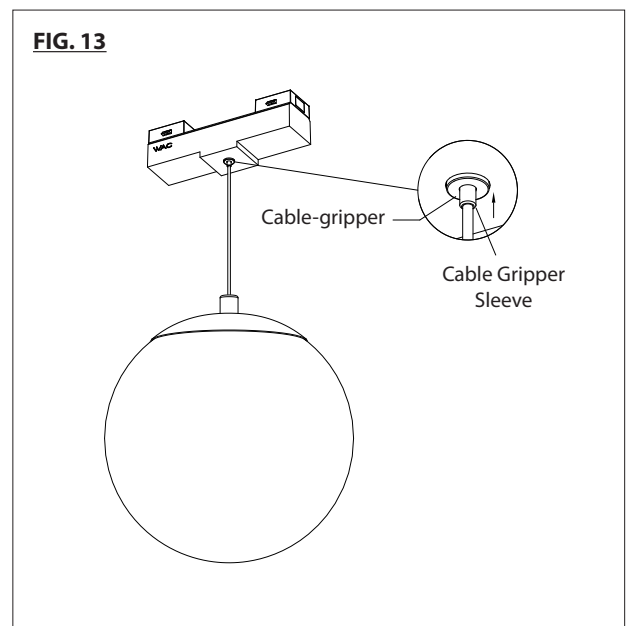
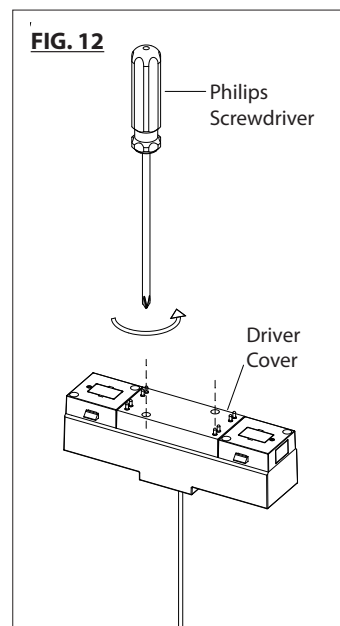

wacighting.com

Phone (800) 526.2588

Fax (800) 526.2585

Headquarters, East Manufacturing Facility

44 Harbor Park Drive

Port Washington, NY 11050

South East Manufacturing Facility

1600 Distribution Ct

Lithia Springs, GA 30122

Central Manufacturing Facility

1700 South J Elmer Freeway, Ste 100

Cedar Hill, TX 75104

West Manufacturing Facility

1750 S Archibald Ave

Ontario, CA 91761

# INSTALLATION INSTRUCTIONS

## VENTRIX - Niveous Pendant

S2PD02-2, S2PD02-3

**VENTRIX**  
BY WAC

3. Undo the electrical connection between the driver cover and suspension cable by lifting the lever on the wire quick connector and removing the suspension cable wires. (See **FIG. 14**).
4. Using the appropriate wire cutter/stripper, cut and remove excess wire, leaving up to 6 inches of suspension cable wire through the adapter (See **FIG. 14**).
5. Using a wire stripper, strip away a section of the clear outer jacket from the suspension cable, to reveal the braided mesh and inner conductor. (See **FIG. 15**)
6. Separate and bundle the braided mesh wires from the inner conductor, and then proceed to strip the inner conductor until the inner most wire is visible. (See **FIG. 15**)
7. Using the wire quick connector, electrically connect the stripped suspension cable to the output wires of the driver cover.
8. Connect the POS(+) inner conductor wire to the wire quick connector housing the RED output wire from the driver cover.
9. Connect the NEG (-) braided mesh wires to the wire quick connector housing the BLACK output wire from the driver cover. (See **FIG. 16**)
9. Place all connected wires and wire quick connectors inside the VENTRIX adapter and reattach the driver cover using the previously removed screws. (See **FIG. 17**) **NOTE:** Ensure all wires properly concealed and are NOT pinched within the VENTRIX adapter. Pinching of wires may result in an electrical short.

**FIG. 14**

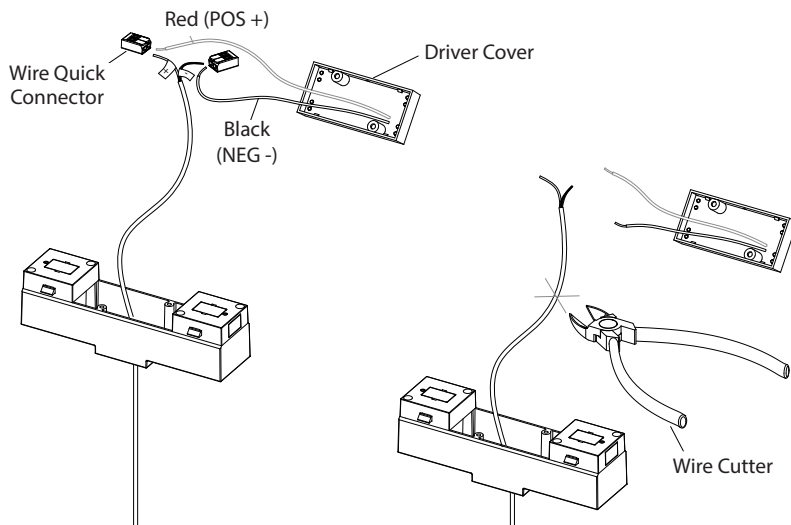

**FIG. 15**

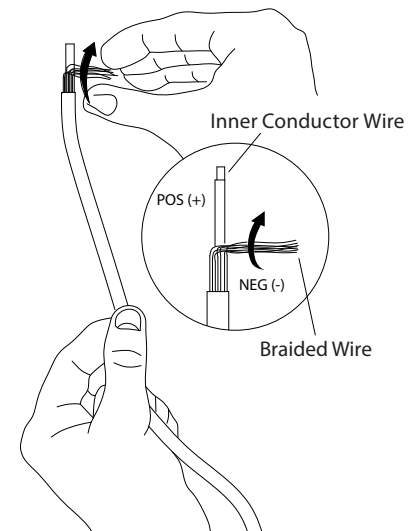

**FIG. 16**

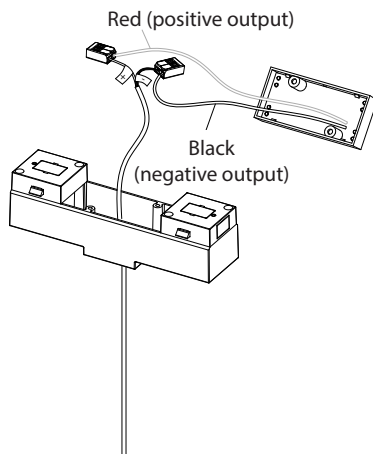

**FIG. 17**

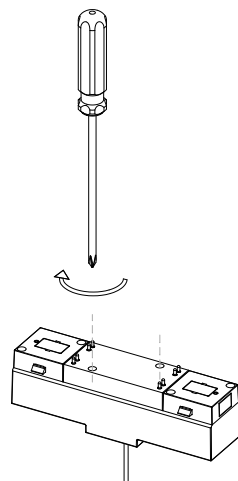

wacighting.com

Phone (800) 526.2588

Fax (800) 526.2585

Headquarters, East Manufacturing Facility

44 Harbor Park Drive

Port Washington, NY 11050

South East Manufacturing Facility

1600 Distribution Ct

Lithia Springs, GA 30122

Central Manufacturing Facility

1700 South J Elmer Freeway, Ste 100

Cedar Hill, TX 75104

West Manufacturing Facility

1750 S Archibald Ave

Ontario, CA 91761

# INSTALLATION INSTRUCTIONS

## VENTRIX - Niveous Pendant

S2PD02-2, S2PD02-3

VENTRIX  
BY WAC

### **For Fine Tuned Suspension Height Adjustment (No Splicing Required)**

Pendant suspensions height adjustments of up to 6 inches may be made without field shortening the cable.

1. The fixture may be installed to or removed from the VENTRIX Channel.
2. Adjust the suspension cable to the desired height, by pushing the sleeve of the cable-gripper. (See **FIG. 18**).

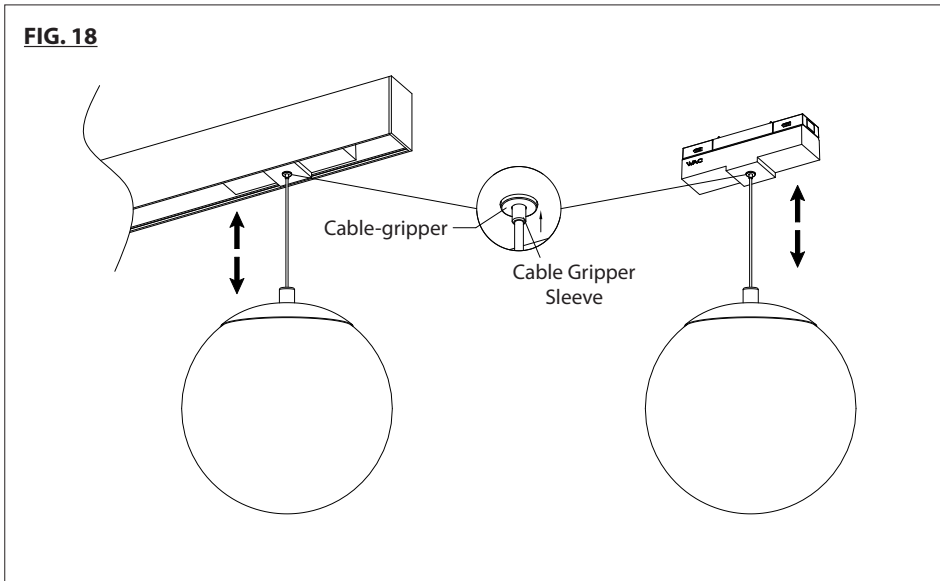

wacighting.com

Phone (800) 526.2588

Fax (800) 526.2585

Headquarters, East Manufacturing Facility

44 Harbor Park Drive

Port Washington, NY 11050

South East Manufacturing Facility

1600 Distribution Ct

Lithia Springs, GA 30122

Central Manufacturing Facility

1700 South J Elmer Freeway, Ste 100

Cedar Hill, TX 75104

West Manufacturing Facility

1750 S Archibald Ave

Ontario, CA 91761