

INSTALLATION INSTRUCTION

Vie - dwelLED™

WS-6614, WS-6620

WAC LIGHTING

Responsible Lighting®

WARNING

IMPORTANT: NEVER attempt any work without shutting off the electricity.

- Read all instructions before installing.
- System is intended for installation by a qualified electrician in accordance with the National Electrical Code and local regulations.
- Go to the main fuse box, or circuit breaker. Place the main power switch in the "OFF" position and unscrew the fuse(s) or switch "OFF" the circuit breaker switch(es) that control the power to the fixture or room that you are working on.
- Place the wall switch in the "OFF" position.

CAUTION

- All parts must be used as indicated in these instructions. Do not substitute any parts, leave parts out, or use any parts that are worn out or broken. Failure to follow this instruction could invalidate the ETL/CETL listing of this fixture. CAUTION When handling the fixture, do not apply pressure to the LEDs. Hold the fixture by the base only.

AVERTISSEMENT

IMPORTANT : Coupez l'électricité avant TOUTE manipulation.

- Lisez toutes les instructions avant d'installer.
- Système est destiné à être installé par un électricien qualifié en conformité avec le code national de l'électricité et les règlements locaux.
- Accédez au panneau central de disjoncteurs ou de fusibles de votre demeure et placez l'interrupteur principal en position d'arrêt (« OFF »).
- Placez l'interrupteur mural en position d'arrêt (« OFF »).

MISE EN GARDE

- Toutes les pièces doivent être utilisées tel qu'il est indiqué dans ces instructions. Ne remplacez pas les pièces, n'en laissez pas de côté et ne les utilisez pas si elles sont usées ou brisées. Le non-respect de ces instructions peut annuler l'homologation ETL/CETL du luminaire. MISE EN GARDE Ors de la manipulation de l'appareil, ne pas appliquer de pression à la LED, tenir l'appareil par la seule base.

ADVERTENCIA

IMPORTANTE: NUNCA intente hacer trabajos sin desconectar el suministro eléctrico.

- Lea y comprenda todas las instrucciones e ilustraciones por completo antes de proceder con el ensamblaje e instalación de esta lámpara.
- Sistema está diseñado para ser instalado por un electricista calificado, de acuerdo con el código eléctrico nacional y las normas locales.
- Diríjase a la caja de fusibles o a la caja del interruptor de circuito principal en su hogar. Coloque el interruptor de alimentación principal en la posición "OFF" (APAGADO).
- Coloque el interruptor de la pared en la posición "OFF" (APAGADO).

PRECAUCIÓN

- Todas las piezas deben usarse como lo indican estas instrucciones. No reemplace las piezas, no omita piezas durante la instalación ni utilice piezas gastadas o rotas. El incumplimiento de esta indicación podría invalidar la calificación ETL/CETL esta lámpara. PRECAUCIÓN Al manipular el aparato, no aplique presión a los LED, mantenga el aparato en la base sólo.

HARDWARE

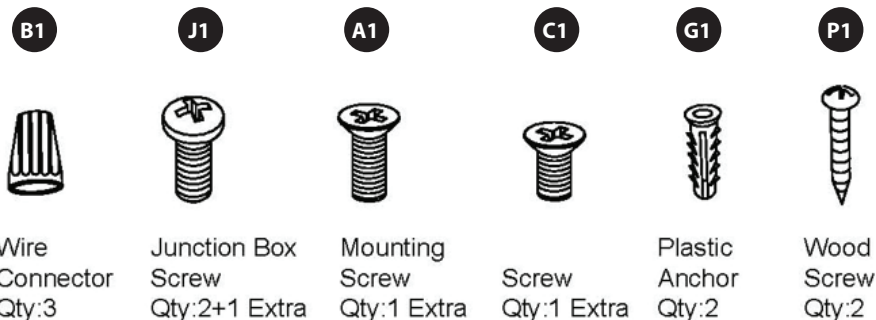

WAC Lighting

www.waclighting.com

Phone (800) 526.2588 • Fax (800) 526.2585

Headquarters/Eastern Distribution Center

44 Harbor Park Drive • Port Washington, NY 11050

Phone (516) 515.5000 • Fax (516) 515.5050

Western Distribution Center

1750 Archibald Ave • Ontario, CA 91761

Phone (800) 526.2588 • Fax (800) 526.2585

INSTALLATION INSTRUCTION

Vie - dwelLED™

WS-6614, WS-6620

WAC LIGHTING

Responsible Lighting®

PREPARATION

1. Shut off the power at the circuit breaker and remove existing fixture, including the crossing bar.

2. Carefully unpack your new fixture and lay out all the parts on a clear area. Be careful not to lose any small parts necessary for installation.

MOUNTING THE FIXTURE (Fig. 1)

3. Remove the screws (A1) from the fixture.

4. Drill holes in the wall aligned with the key hole location in mounting plate (E1). Insert plastic anchors (G1) into holes.

5. Secure the mounting plate (E1) to the junction box (F1) using junction box screws (J1). The side of the mounting plate marked "GND" must face out.

6. Place the glass (M1) into the ring (L1). Secure onto the fixture back plate using screws (C1) from back.

7. Fasten wood screws (P1) into plastic anchors (G1) and hold the mounting plate (E1) tight.

CONNECTING THE WIRES (Fig. 2)

8. Connect the input wires to junction box wires as shown in Fig. 2, making sure that all wire connectors (B1) are secured. If your outlet box has a green or bare copper ground wire, connect the fixture's ground wire to it. Otherwise, connect the fixture's ground wire directly to the back plate (E1) using the green screw provided. After wires are connected, tuck them carefully inside the junction box.

MOUNTING THE FIXTURE (Fig. 1)

9. Place the fixture over the mounting plate (E1) and secure with screws (A1).

FIG.1

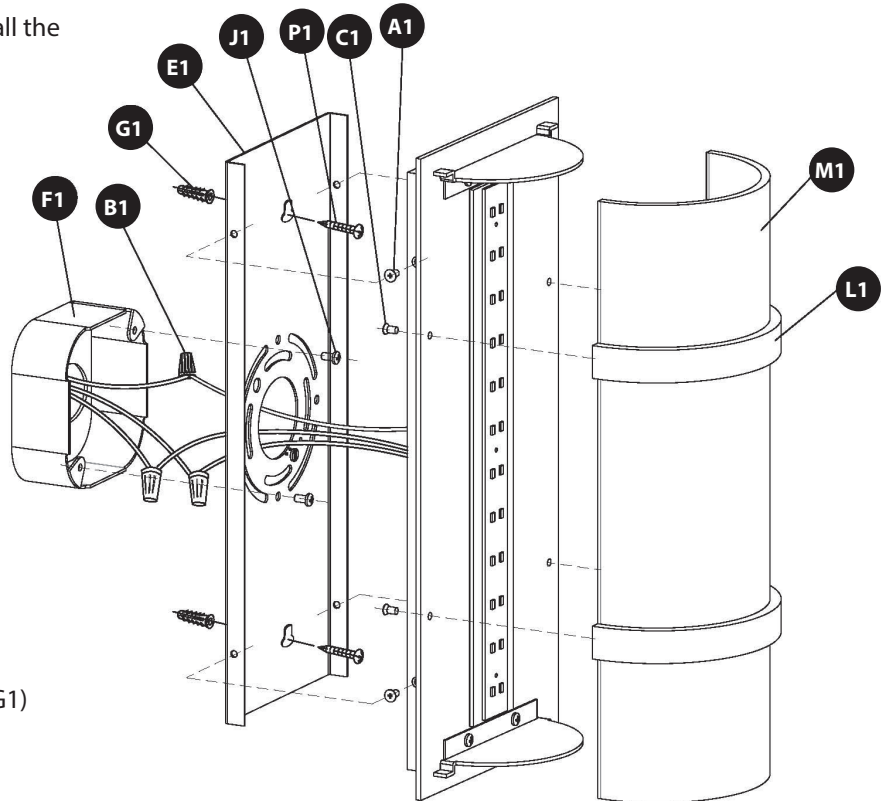

100%-10% DIMMING

COMPATIBLE WITH THE FOLLOWING ELECTRONIC LOW VOLTAGE (ELV) DIMMERS

Brand	Model
LUTRON	SELV-300P
LUTRON	DVELV-300P
LEVITON	MLE03-1

FIG.2

Fixture Wires

Black or Smooth

Fixture Wires

White or Ribbed

Fixture Wires

Bare Copper (Ground)

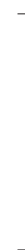

House Wires

Black (Hot)

House Wires

White (Neutral)

House Wires

Green or Bare Copper (Ground)

WAC Lighting

www.waclighting.com

Phone (800) 526.2588 • Fax (800) 526.2585

Headquarters/Eastern Distribution Center

44 Harbor Park Drive • Port Washington, NY 11050

Phone (516) 515.5000 • Fax (516) 515.5050

Western Distribution Center

1750 Archibald Ave • Ontario, CA 91761

Phone (800) 526.2588 • Fax (800) 526.2585

INSTALLATION INSTRUCTION

Vie - dwelLED™

WS-6618, WS-6624, WS-6636

WAC LIGHTING

Responsible Lighting®

WARNING

IMPORTANT: NEVER attempt any work without shutting off the electricity.

- Read all instructions before installing.
- System is intended for installation by a qualified electrician in accordance with the National Electrical Code and local regulations.
- Go to the main fuse box, or circuit breaker. Place the main power switch in the "OFF" position and unscrew the fuse(s) or switch "OFF" the circuit breaker switch(es) that control the power to the fixture or room that you are working on.
- Place the wall switch in the "OFF" position.

CAUTION

- All parts must be used as indicated in these instructions. Do not substitute any parts, leave parts out, or use any parts that are worn out or broken. Failure to follow this instruction could invalidate the ETL/CETL listing of this fixture. CAUTION When handling the fixture, do not apply pressure to the LEDs. Hold the fixture by the base only.

AVERTISSEMENT

IMPORTANT : Coupez l'électricité avant TOUTE manipulation.

- Lisez toutes les instructions avant d'installer.
- Système est destiné à être installé par un électricien qualifié en conformité avec le code national de l'électricité et les règlements locaux.
- Accédez au panneau central de disjoncteurs ou de fusibles de votre demeure et placez l'interrupteur principal en position d'arrêt (« OFF »).
- Placez l'interrupteur mural en position d'arrêt (« OFF »).

MISE EN GARDE

- Toutes les pièces doivent être utilisées tel qu'il est indiqué dans ces instructions. Ne remplacez pas les pièces, n'en laissez pas de côté et ne les utilisez pas si elles sont usées ou brisées. Le non-respect de ces instructions peut annuler l'homologation ETL/CETL du luminaire. MISE EN GARDE Lors de la manipulation de l'appareil, ne pas appliquer de pression à la LED, tenir l'appareil par la seule base.

ADVERTENCIA









IMPORTANTE: NUNCA intente hacer trabajos sin desconectar el suministro eléctrico.

- Lea y comprenda todas las instrucciones e ilustraciones por completo antes de proceder con el ensamblaje e instalación de esta lámpara.
- Sistema está diseñado para ser instalado por un electricista calificado, de acuerdo con el código eléctrico nacional y las normas locales.
- Diríjase a la caja de fusibles o a la caja del interruptor de circuito principal en su hogar. Coloque el interruptor de alimentación principal en la posición "OFF" (APAGADO).
- Coloque el interruptor de la pared en la posición "OFF" (APAGADO).

PRECAUCIÓN

- Todas las piezas deben usarse como lo indican estas instrucciones. No reemplace las piezas, no omita piezas durante la instalación ni utilice piezas gastadas o rotas. El incumplimiento de esta indicación podría invalidar la calificación ETL/CETL esta lámpara. PRECAUCIÓN Al manipular el aparato, no aplique presión a los LED, mantenga el aparato en la base sólo.

HARDWARE

									
Wire Connector Qty:3	Junction Box Screw Qty:2+1 Extra	Mounting Screw Qty:1 Extra	Screw Qty:1 Extra	Mounting Anchor Qty:2	Wood Screw Qty:2	Metal Tube Qty:2	Mounting Ring Qty:1	Conversation Plate Qty:1	Screw Qty:2+1 Extra

WAC Lighting

www.waclighting.com

Phone (800) 526.2588 • Fax (800) 526.2585

Headquarters/Eastern Distribution Center

44 Harbor Park Drive • Port Washington, NY 11050

Phone (516) 515.5000 • Fax (516) 515.5050

Western Distribution Center

1750 Archibald Ave • Ontario, CA 91761

Phone (800) 526.2588 • Fax (800) 526.2585

FIG.1

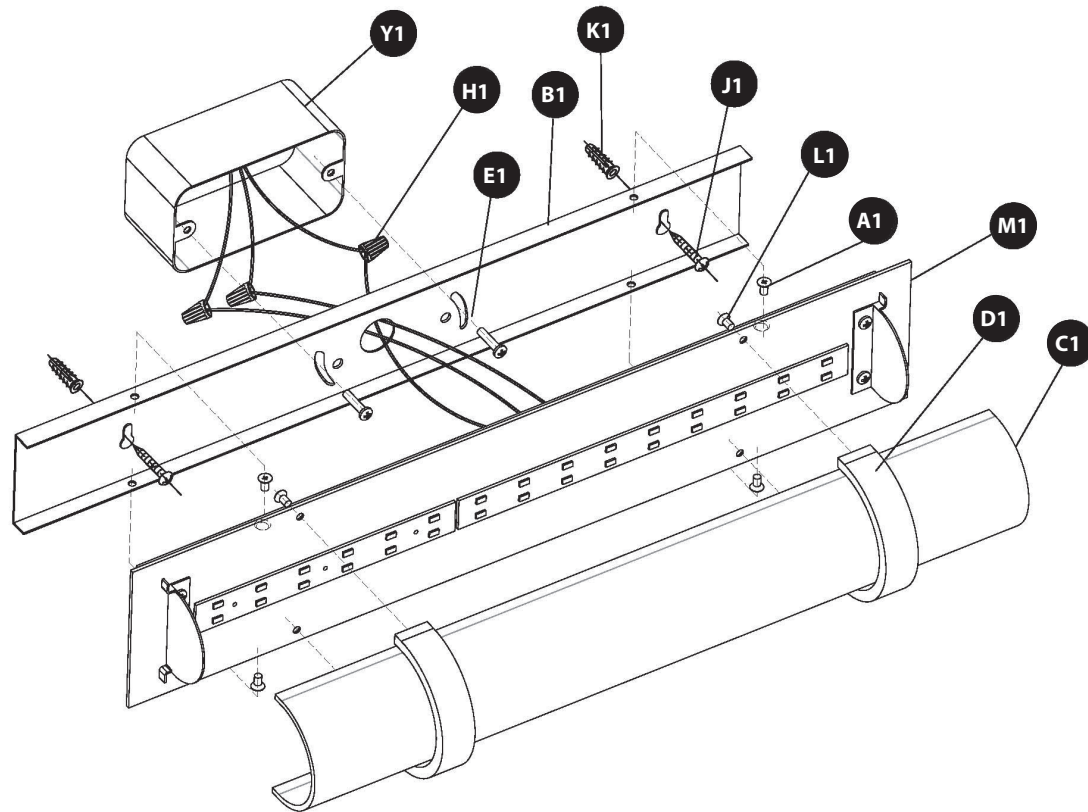

PREPARATION

1. Shut off the power at the circuit breaker and remove existing fixture including the mounting hardware.
2. Carefully unpack your new fixture and lay out all the parts on a clear area. Be careful not to lose any small parts necessary for installation.

MOUNTING THE FIXTURE (Fig. 1)

3. Remove the mounting screws (A1) from the fixture.
4. Place the glass (C1) into the ring (D1), secure from the back of fixture back plate (M1) using screws (L1).
5. Drill holes in the wall aligned with the key-hole location in the mounting plate (B1). Insert the mounting anchors (K1).

FOR SWITCH BOX (Fig. 1)

6. Secure the mounting plate (B1) to the switch box (Y1) using the junction screws (E1). The side of the mounting plate marked "GND" (B1) must face out.
7. Fasten the wood screws (J1) into the mounting anchors (K1). Tighten the mounting plate (B1) to the wall.

FIG.2

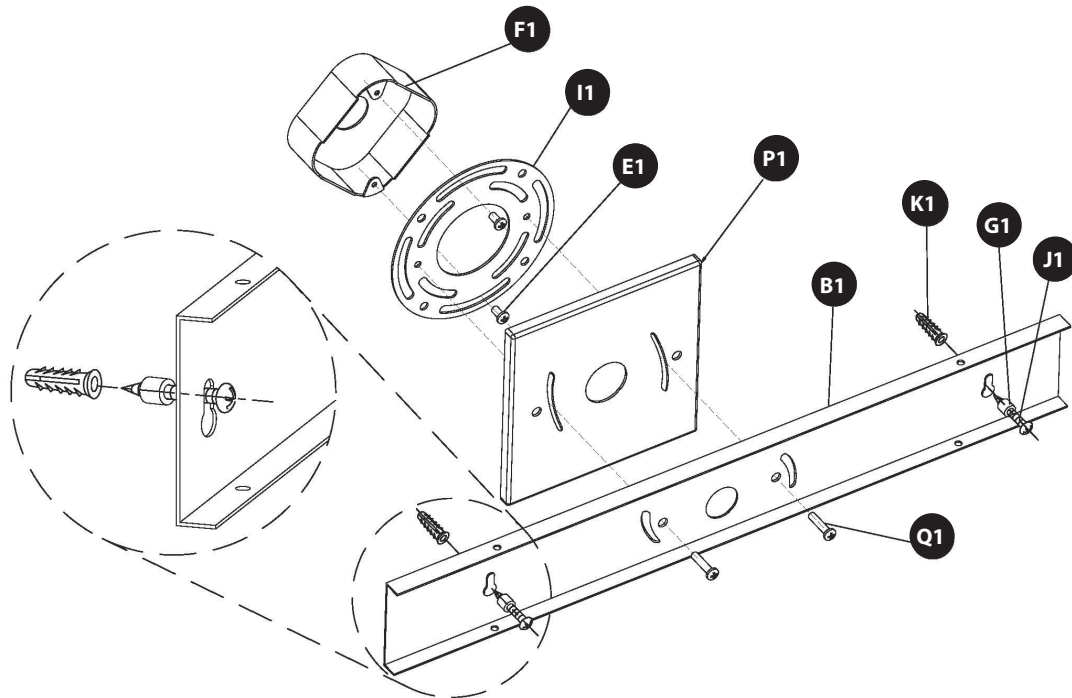

FOR JUNCTION BOX (Fig. 2, if necessary)

8. Secure the mounting ring (I1) to the junction box (F1) using the junction screws (E1). Make sure the two threaded holes (spacing 2-3/4") are horizontal as shown in Fig. 2.

9. Put the mounting plate (B1) and the conversion plate (P1) onto the mounting ring (I1). Align the two holes on mounting plate (B1), the slots on conversion plate (P1) and the two threaded holes (spacing 2-3/4") on mounting ring (I1). Fasten using screws (Q1).

10. Fasten the wood screws (J1) and metal tube (G1) into the mounting anchors (K1). Make sure the metal tube (G1) is between the wall and the mounting plate (B1), hold the mounting plate (B1) well. Tighten the mounting plate (B1) to the wall.

CONNECTING THE WIRES (Fig. 3)

10. Connect the electrical wires as shown in Fig. 3, making sure that all wire connectors are secured. If your outlet box has a green or bare copper ground wire, connect the fixture's ground wire to it. Otherwise, connect the fixture's ground wire directly to the mounting plate (B1) or mounting ring (I1) using the green screw provided. After wires are connected, tuck them carefully inside the junction box.

11. Place the fixture over the mounting plate (B1) and secure with screws (A1).

**100%-10% DIMMING
 COMPATIBLE WITH THE FOLLOWING ELECTRONIC
 LOW VOLTAGE (ELV) DIMMERS**

Brand	Model
LUTRON	SELV-300P
LUTRON	DVELV-300P
LEVITON	MLE03-1

FIG.3

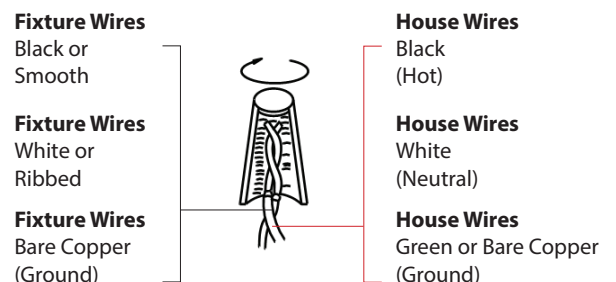

INSTALLATION INSTRUCTION

Trimless Junction Box Cover

CP-TL-WT



CAUTION: TO PREVENT ELECTRICAL SHOCK, ENSURE ELECTRICITY HAS BEEN TURNED OFF AT THE CIRCUIT BREAKER BEFORE BEGINNING.

- Read all instructions before installing.
- System is intended for installation by a licensed electrician in accordance with the National Electrical Code (NEC) and local regulations.
- When handling the fixture, do not apply pressure to the LEDs. Hold the fixture by the base only.
- Retain installation instructions for future maintenance reference.

WARNING: All parts must be used as indicated in these instructions. This product is designed for use only with the supplied parts and/or accessories designated for use by WAC Lighting. Substitution of parts or accessories not designated for use with this product by WAC Lighting could result in personal injury or property damage, and will void the warranty. Contact an authorized dealer or the manufacturer if any parts are damaged or missing.

MISE EN GARDE: POUR ÉVITER TOUT CHOC ÉLECTRIQUE, ASSUREZ-VOUS QUE LE DISJONCTEUR SOIT MIS HORS TENSION AVANT DE COMMENCER.

- Lisez toutes les instructions avant l'installation.
- Le système doit être installé par un électricien licencié conformément au code national de l'électricité (NEC), et également aux règlements locaux.
- Lors de la manipulation du luminaire, n'appuyez pas sur les LED. Tenez-le uniquement par la base.

ATTENTION: Toutes les pièces doivent être utilisées comme indiqué dans ces instructions. Ce produit est conçu pour être utilisé seulement avec les pièces et/ou accessoires fournis pour être utilisés avec les produits WAC Lighting. Remplacer des pièces ou accessoires non conçus pour ce produit WAC Lighting pourrait causer des dommages corporels ou matériels et pourrait également causer l'annulation de la garantie. Veuillez contacter un revendeur autorisé ou le fabricant si des pièces manquent ou sont endommagées.

COMPONENT OVERVIEW

The trimless junction box cover is intended for installation to NEC approved 4" square junction boxes recessed in drywall and flush with the support structure. It may be covered with spackle and/or plaster to conceal junction box visibility. It is to be connected to compatible WAC fixtures and track lighting components. Refer to specifications sheets for more information on connector compatibility.

OVERALL COMPONENT DIMENSIONS

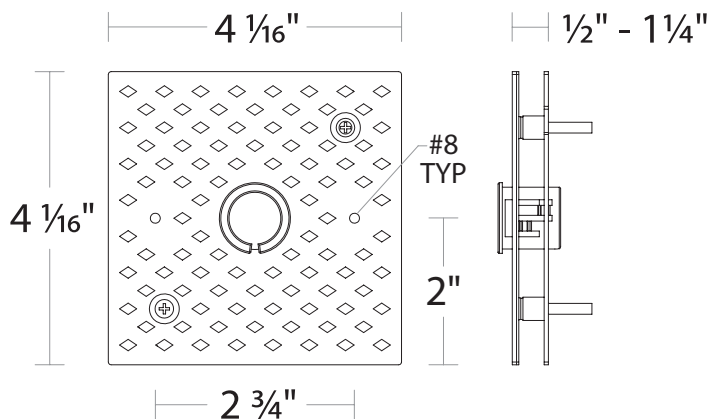

HARDWARE

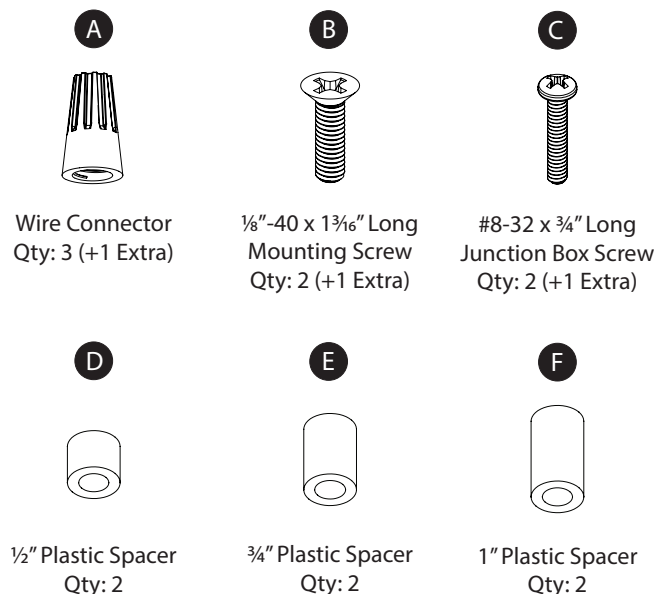

waclighting.com
Phone (800) 526.2588
Fax (800) 526.2585

Headquarters/Eastern Distribution Center
44 Harbor Park Drive
Port Washington, NY 11050

Central Distribution Center
1600 Distribution Ct
Lithia Springs, GA 30122

Western Distribution Center
1750 Archibald Avenue
Ontario, CA 91760



INSTALLATION INSTRUCTION

Trimless Junction Box Cover

CP-TL-WT



TRIMLESS JUNCTION BOX COVER INSTALLATION:

The trimless junction box cover is compatible with NEC approved 4" square junction boxes recessed in drywall and flush with the support structure.

1. Install compatible junction box (by others) to the framing structure. Ensure the junction box is flush with the base or front of framing structure (See FIG. 1).
2. Install the mounting plate to the junction box (See FIG. 2). Ensure the spacer alignment base is facing outward.

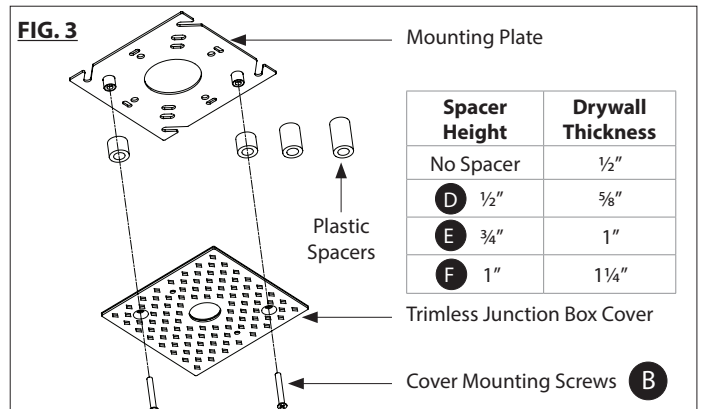
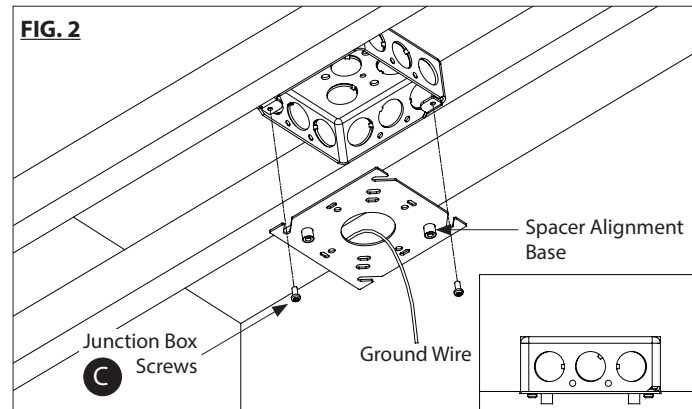
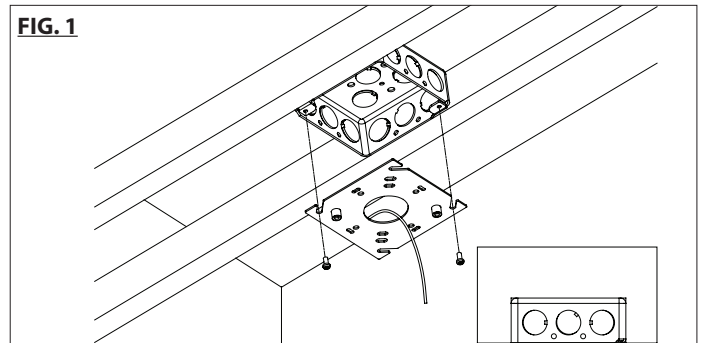

3. Determine the drywall thickness and select the appropriate spacer to install between the mounting plate and the trimless junction box cover (See FIG. 3).
NOTE: Only 1 matching pair of spacers are to be used per installation.
4. Using the mounting screws provided, attach the trimless junction box cover to the mounting plate (See FIG. 4).
5. Make a 4 1/8" square cutout in drywall at the intended trimless junction box cover location and proceed to install to framing structure (See FIG. 5). Apply and finish spackle up to the center hole of trimless junction box cover. Ensure #8 holes on the cover are free of spackle. (See FIG. 6).

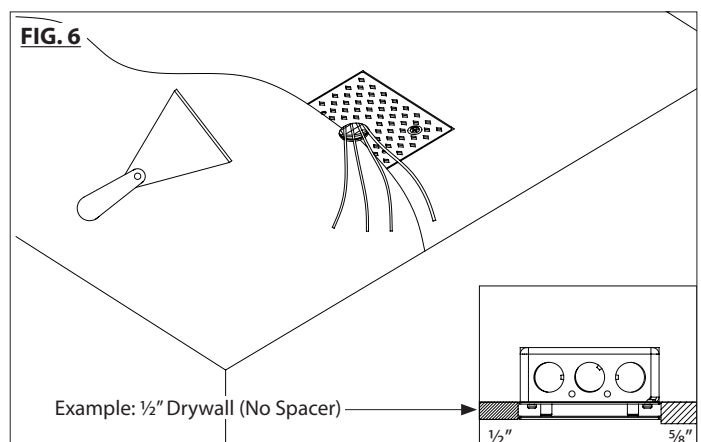
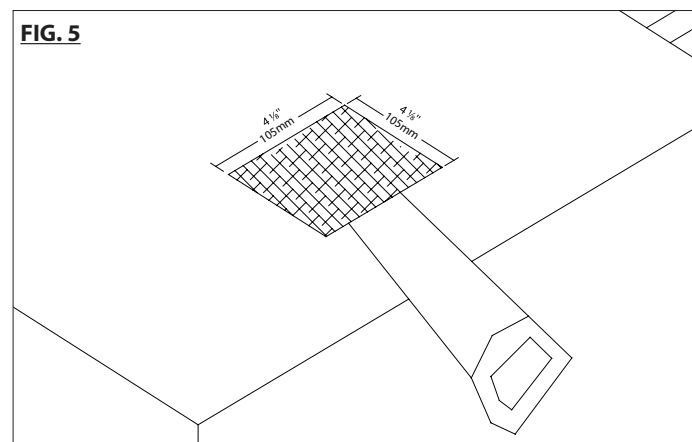
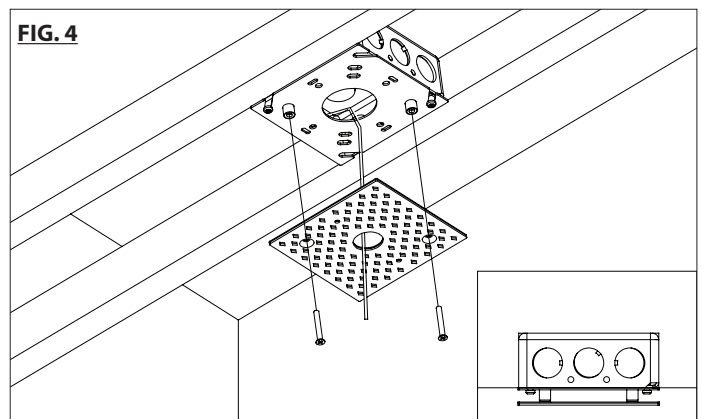

waclighting.com
Phone (800) 526.2588
Fax (800) 526.2585

Headquarters/Eastern Distribution Center
44 Harbor Park Drive
Port Washington, NY 11050

Central Distribution Center
1600 Distribution Ct
Lithia Springs, GA 30122

Western Distribution Center
1750 Archibald Avenue
Ontario, CA 91760



INSTALLATION INSTRUCTION

Trimless Junction Box Cover

CP-TL-WT



FIXTURE INSTALLATION TO JUNCTION BOX COVER (USING C-RING):

The trimless junction box cover is supplied with a mounting C-ring that is compatible with 7/8" knockouts. This mounting C-ring is used to secure the fixture to the trimless junction box cover.

1. Remove 7/8" knockout material from the fixture or connector. Bring the building and ground wires through the fixture knockout and mounting C-ring. (See **FIG. 7**).
2. Make appropriate splice connections. Wiring may be placed inside the fixture or pushed into the junction box. Apply fixture cover or lensing (where applicable) to complete the installation. (See **FIG. 8**).

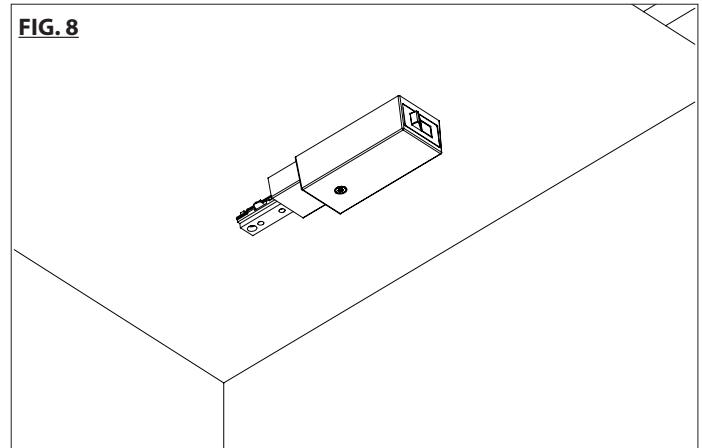
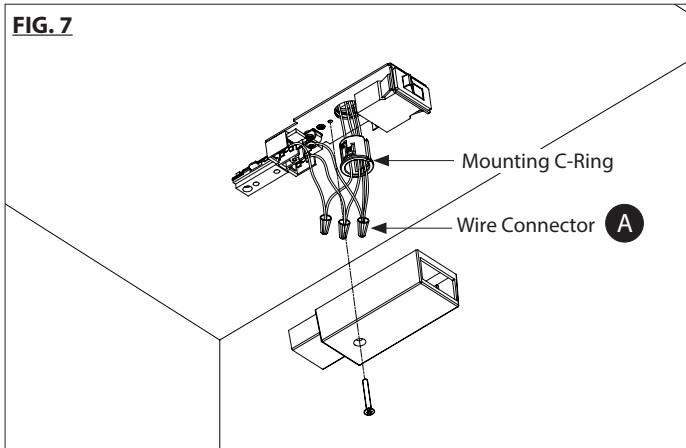

FIXTURE INSTALLATION TO JUNCTION BOX COVER (USING #8 HOLES ON COVER):

The trimless junction box cover features two #8 holes which may be used to mount fixtures:

1. Make appropriate splice connections. Wiring may be placed inside the fixture or pushed into the junction box.
2. Using #8 mounting screws supplied with the lighting fixture, attach the fixtures to the #8 holes on the trimless junction box cover. Apply fixture cover or lensing (where applicable) to complete the installation. (See **FIG. 9**).

