

INSTALLATION INSTRUCTIONS

1076-LED Wall Sconce

WS107615 / WS107624 / WS107633

dweLED

CAUTION: To prevent electrical shock, ensure electricity has been turned off at the circuit breaker before beginning.

- Read all instructions before installing.
- System is intended for installation by a licensed electrician in accordance with the National Electrical Code (NEC) and local regulations.
- When handling the fixture, do not apply pressure to the LEDs. Hold the fixture by the base only.
- Retain installation instructions for future maintenance reference.

WARNING: All parts must be used as indicated in these instructions. This product is designed for use only with the supplied parts and/or accessories designated for use by dweLED. Substitution of parts or accessories not designated for use with this product by dweLED could result in personal injury or property damage, and will void the warranty. Contact an authorized dealer or the manufacturer if any parts are damaged or missing.

MAINTENANCE NOTE: Coastal conditions may cause mineral and residue build-up on the fixture. We recommend that customers in coastal areas clean all external surfaces of the fixture once every two weeks with a wet cloth.

MISE EN GARDE: Pour éviter tout choc électrique, assurez-vous que le disjoncteur soit mis hors tension avant de commencer.

- Lisez toutes les instructions avant l'installation.
- Le système doit être installé par un électricien licencié conformément au code national de l'électricité (NEC), et également aux règlements locaux.
- Lors de la manipulation du luminaire, n'appuyez pas sur les LED. Tenez-le uniquement par la base.

ATTENTION: Toutes les pièces doivent être utilisées comme indiqué dans ces instructions. Ce produit est conçu pour être utilisé seulement avec les pièces et/ou accessoires fournis pour être utilisés avec les produits dweLED. Remplacer des pièces ou accessoires non conçus pour ce produit dweLED pourrait causer des dommages corporels ou matériels et pourrait également causer l'annulation de la garantie. Veuillez contacter un revendeur autorisé ou le fabricant si des pièces manquent ou sont endommagées.

NOTE D'ENTRETIEN: Les conditions côtières peut causer une accumulation de minéraux et de résidus sur le luminaire. Nous recommandons aux clients qui résident dans les zones côtières de nettoyer toutes les surfaces externes du luminaire une fois toutes les deux semaines avec un chiffon humide.

HARDWARE

A

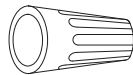

Wire Connector
Qty: 3PCS+1 Extra

B



Back Plate Screw
Qty: 1 Extra

wacighting.com
Phone (800) 526.2588
Fax (800) 526.2585

Headquarters, East Manufacturing Facility
44 Harbor Park Drive
Port Washington, NY 11050

South East Manufacturing Facility
1600 Distribution Ct
Lithia Springs, GA 30122

Central Manufacturing Facility
1700 South J Elmer Freeway, Ste 100
Cedar Hill, TX 75104

West Manufacturing Facility
1750 S Archibald Ave
Ontario, CA 91761

INSTALLATION INSTRUCTIONS

1076-LED Wall Sconce

WS107615 / WS107624 / WS107633

dweLED

Fig.1

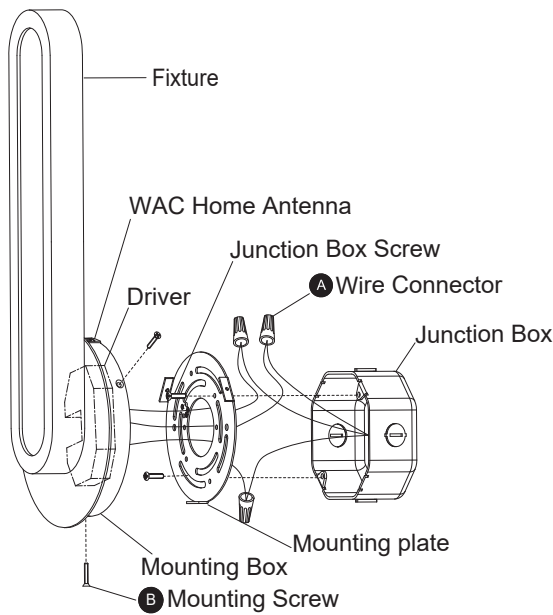

WS107615

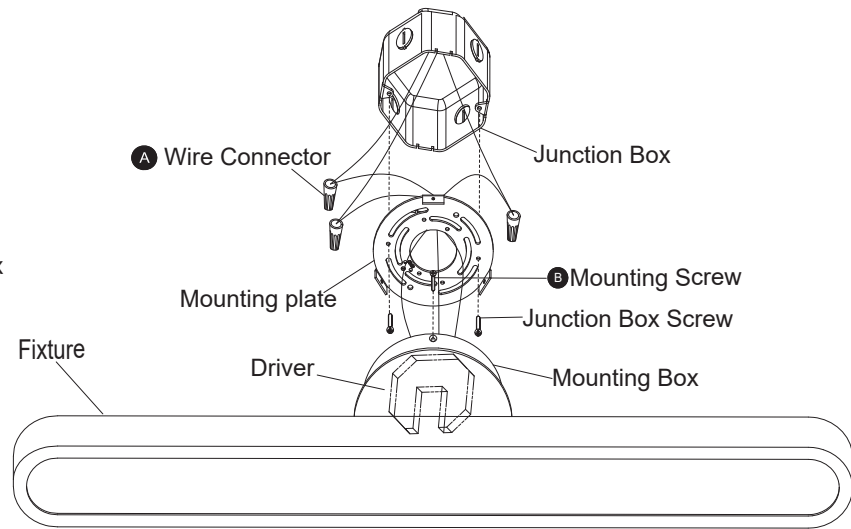

WS107624&WS107633

PREPARATION

1. Shut off the power at the circuit breaker and remove existing fixture, including the crossbar.
2. Carefully unpack your new fixture and lay out all the parts in a clear area. Be careful not to lose any small parts necessary for installation.

MOUNTING THE FIXTURE (Fig. 1)

3. Remove the mounting screw (B) from the fixture.
4. Secure the mounting plate to the junction box using the original junction box screws.

- Note: (i) It is recommended to use only original junction box screws or replacements provided by junction box manufacturer.
 (ii) The side of the wall plate marked "GND" must face out towards the installer.

CONNECTING THE WIRES (Fig. 2)

5. Connect the Driver input wires to junction box as shown in Fig.2. making sure that all wire connectors (A) are secured. If your outlet box has a green or bare copper ground wire, connect the fixture's ground wire to it. Otherwise, connect the fixture's ground wire directly to the mounting plate using the GND screw provided. After wires are connected, tuck them carefully inside the junction box.

COMPLETING THE INSTALLATION

6. Secure the fixture to the mounting plate using the mounting screws (B).

Fig. 2 Wiring

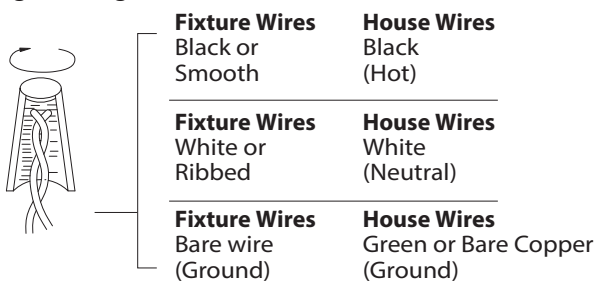

Mounting Plate

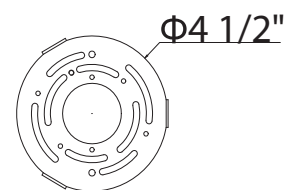

wacighting.com
 Phone (800) 526.2588
 Fax (800) 526.2585

Headquarters, East Manufacturing Facility
 44 Harbor Park Drive
 Port Washington, NY 11050

South East Manufacturing Facility
 1600 Distribution Ct
 Lithia Springs, GA 30122

Central Manufacturing Facility
 1700 South J Elmer Freeway, Ste 100
 Cedar Hill, TX 75104

West Manufacturing Facility
 1750 S Archibald Ave
 Ontario, CA 91761